

TECHNICAL DATASHEET



EF COUPLER

04 Update - 06/2023

TECHNICAL DATA

Article No	101 117 2160 0450
d (mm)	450
D (mm)	560
Z (mm)	320
m (mm)	75
Weight (Kg)	20,03
Box Quantity (pcs)	1
Box Dimension (cm)	58X58X33

INJECTION MOULDED

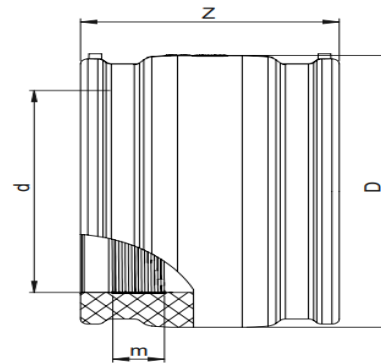

IDENTIFICATION OF PRODUCT

D(mm)	450
SDR	11
RAW MATERIAL	PE 100
PRESSURE CLASS	16 Bar Water 10 Bar Gas
TRADEMARK	NTG
EXECUTION	Injection Moulded
STANDARD	EN 12201-3 EN 1555-3 AS / NZS 4129
SPECIFICATION	Suitable for SDR11....13,6 pipe 4 mm pin connectors

EF SPECIFICATION

WELDING VOLTAGE	40 V
RESISTANCE	0,560 Ω
WELDING TIME	2220 Sec.
COOLING TIME	45 Min.
WINDING TYPE	Monofilar
WELDING BARCODE	

Tolerance on diameters and thickness according to the standards. The other dimensions are specialized. Tolerance $\pm 5\%$. NTG PLASTIK reserves all the right to change any information without giving prior notice. The production, distribution and utilization of this document without explicit authorization is prohibited.